

### ALL PURPOSE PETRO-INDUSTRIAL UNIT

As either plant or field equipment Water Trotter provides an economical one to one weight ratio for a variety of workloads and payloads. That's partly because of optional diesel or gas engines.

#### STRUCTURED TO THE NEED

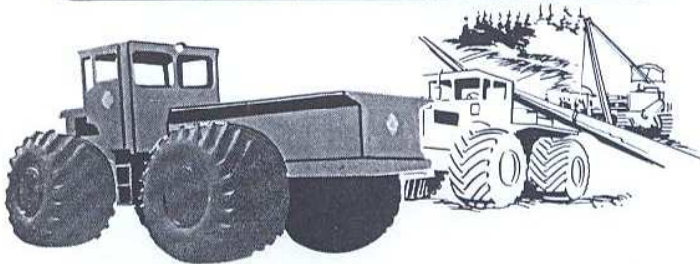

### RUGGED FOR MINING USE

Ore carrier or equipment hauler, Water Trotter all steel construction provides for more adaptable on-site maintenance with implementation. Overstressed at 2 to 1 this unit can be utilized for the most demanding ore carrying or equipment distribution.

#### LOW MAINTENANCE FACTOR

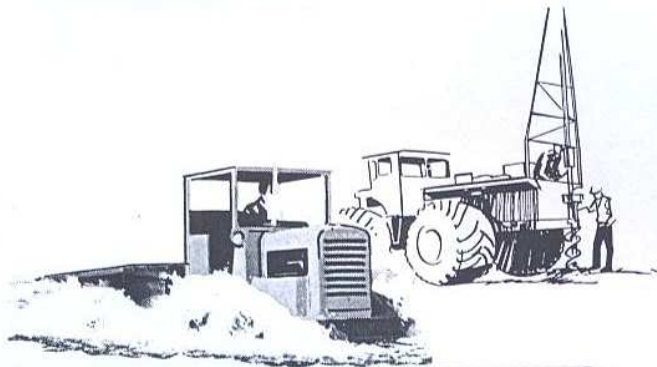
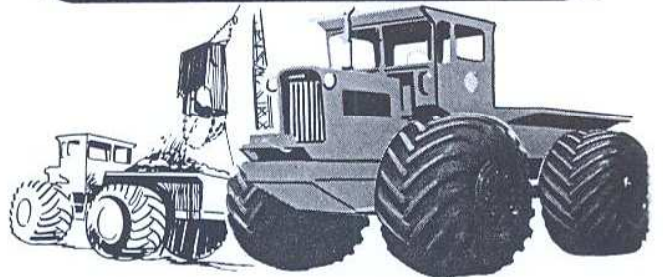

### DEPENDABLE PIPELINING MOBILITY

As a low cost backhoe or for over-the-hole pipelining or draglining, Water Trotter has few equals. According to the need, switching tractor tires to wide ribbed balloons is as simple as that for an automobile. Cold weather dependability is also ensured with tube tire availability.

#### WIDE STANCE SLOPE STABILITY

### EXPLORATION AMPHIBILITY

In variable applications, Water Trotter is a superior performer in water, snow and tundra. Full lateral articulation, preventing tundra tearing, conforms with BLM specifications. It's indestructible "swivel and stopper" coupling provides turns within 2 degree maximum allowable.

#### AIRLIFT TWO IN A HERC!

# Flextrac WATER TROTTER

## MODEL FN-WT 100 SPECIFICATIONS

Standard Unit includes the following:

<b>PAYLOAD</b>	10,000 Lbs.
<b>GVW w/PAYLOAD</b>	22,000 Lbs.
<b>PSI (loaded)</b>	5 PSI at 0" penetration
<b>AXLES</b>	Rockwell — Planetary PR 100 Series 4 Wheel Drive
<b>BRAKES</b>	Fail — safe Mechanical Drum Brake
<b>STEERING</b>	Hydraulic Power w/3" dia Cylinder for articulated pivot centre steering.
<b>TURNING RADIUS</b>	Inside Tyres — 17' Outside Tyres — 33'
<b>MANEUVERABILITY</b>	Frame Oscillation — 20 pivot centre articulation : 45
<b>TYRES &amp; WHEELS</b>	Standard 43 × 66 × 25 Rim Special Rim
<b>FRAME</b>	Steel, articulated centre pivot, on front axle bearing trunnion allowing frame oscillation.
<b>ENGINE</b>	Ford Industrial Gasoline V8 330 Cu.In. 150 BHP 12V Electric starter, generator and voltage regulators, centrifugal flyball governor, dry type air cleaner, standard fuel and oil filters, mechanical fuel pump.
<b>GEAR TRAIN</b>	New process transmission — 435L — four (4) speeds forward, one reverse, synchromesh gears w/12" heavy duty clutch (12 speeds forward & three speeds reverse with the use of the transfer case).
<b>TRANSFER CASE</b>	New Process Series 200
<b>ELECTRICAL SYSTEM</b>	12 Volt w/53 Amp-hour battery
<b>INSTRUMENTS</b>	Ammeter, push-button starting, choke control, shut- down switch
<b>CANOPY</b>	Furnished with top brush guard.
<b>OVERALL WIDTH</b>	107" (standard tread width 119")
<b>OVERALL LENGTH</b>	240", Wheel Base — 120"
<b>OVERALL HEIGHT</b>	To top of Canopy — 113"
<b>GROUND CLEARANCE</b>	25" at Axle, 30" at pivot point.
<b>FUEL TANK CAPACITY</b>	Dual Tanks — 40 Gal. Total
<b>GROUND SPEED</b>	to 40 m.p.h.

### OPTIONAL EQUIPMENT

<b>A. WINCH</b>	12,000 lb. capacity w/125 ft. $\frac{3}{8}$ cable, hook & fairleads.
<b>B. PAINT</b>	Special colour on request
<b>C. CARGO BOX</b>	or other additional equipment mounted on rear frame

DISTRIBUTED BY:

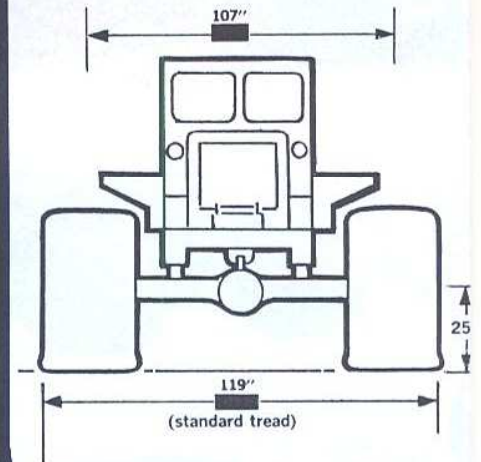

# Flextrac Nodwe

P.O. BOX 5544, STATION A - 1201 42nd AVE. S.E., CALGARY  
TELEPHONE 287-2280 - AREA CODE 403 - TELEX NO.

# Flextrac Nodwell

complements their off-road  
carrier series with the  
versatile, economical

# WATER TROTTER

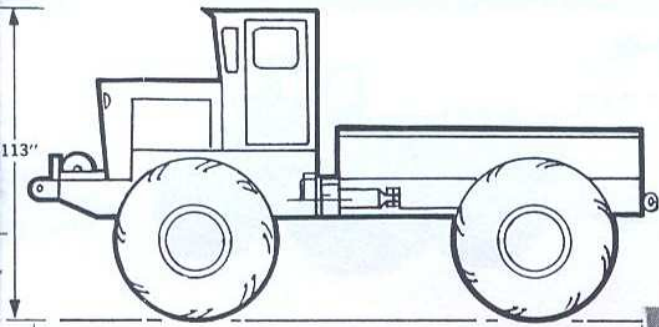

**C**  
II  
Y, ALBERTA  
038-21566

# WATER TROTTER

## the ALL Canadian tractor story

Conceived and manufactured to meet an industrial and agricultural demand for improved amphibious capability, the Water Trotter evolved in Western Canada as the dependable alternative to other such wheeled tractors.

The addition of the Water Trotter to the world renowned Flextrac Nodwell track carrier line is ample testimony to the high standard of engineering and performance potential inherent in the FN WT 100.

The increased need for an amphibious vehicle to complement tracked equipment has long been apparent to Flextrac Nodwell. As a result, they have manufacturing and sales rights to this terra-tired tractor. Presently in service in Canada's North, the Water Trotter has proven to be a low maintenance, all purpose machine that puts the meaning of **pay** back into payload. It has hi-speed, off-road capability that can be depended upon to function in water, swamp, snow, mud and muskeg conditions.

Its parts and service availability is under the Flextrac Nodwell system, who already provide for **world-wide** tracked carrier distribution.

**Flextrac**  
Nodwell

### VERSATILE FARM VEHICLE

For less investment than tractors and combinations Water Trotter can manipulate most inaccessible agricultural terrain with greater workload.

**PULL-CARRY COMBINATION  
TO 10,000 LBS.**

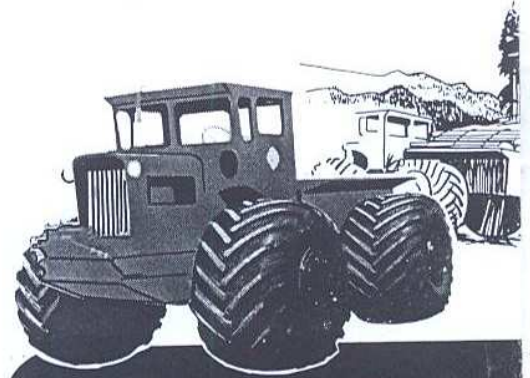
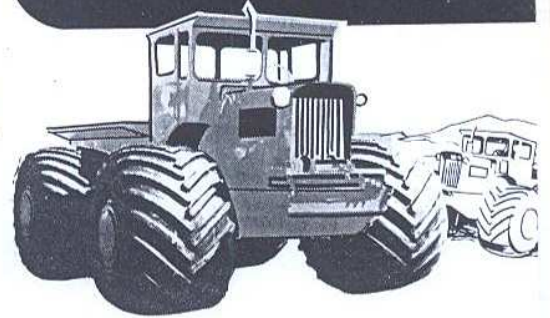

### HIGH SPEED LOGGING OPERATOR

With either gas or diesel power, and clearance, the Water Trotter is designed as an able skidder! Its also power packed for land and water forestry uses.

**10,000 LB. PAYLOAD CAPABILITY**